



EVENT RESOURCE GUIDE

CONTENTS

GENERAL

- Contact Information.....2
- Booking Procedures.....2
- Ticketing & Seating.....3
- Staffing.....3
- Catering.....3
- Merchandise.....4
- Directions to Facility.....4
- Parking Map.....5
- Event Marketing Services.....6
- Graphic Specifications & Sizes.....7
- Scoreboard Dimensions.....8
- Rental Rates.....9
- Transportation.....9
- Local Resources.....10

ARENA.....11

- Load In.....12
- Rigging.....14
- Power.....15
- Staging.....15
- Curtains.....15
- Spotlights.....16
- Forklifts.....16
- Pyro/Haze.....17
- House Capacity.....17
- Seating Chart Sample.....18
- Set Up Photos.....19
- Dressing Rooms & Backstage Area.....20

EXPO CENTER.....25

- Load-In.....26
- Capacities/Set-Ups.....27
- Seating Chart Samples.....29
- Rigging.....31
- Power.....32
- Staging.....32
- First Floor Master Plan.....33
- Equipment.....34
- Dressing Rooms & Offices.....35

Contact Information

Executive VP & General Manager	Melanie Carney	260-482-9502	mcarney@memorialcoliseum.com
Vice President of Operations	Eric Lonsbury	260-480-2129	elonsbury@memorialcoliseum.com
Assistant Operations Manager	Rich Thoma	260-480-2172	rthoma@memorialcoliseum.com
Director of Ticketing	April Workman	260-483-1111	cto@memorialcoliseum.com
Ticket Office Manager	Patrick Ventura	260-483-1111	cto@memorialcoliseum.com
Aramark Food & Beverage General Manager	Ed Davidson	260-484-6486	edavidson@memorialcoliseum.com
Marketing Communications Coordinator	Chelsea Wilson	260-480-3709	cwilson@memorialcoliseum.com
BA-Local 146	Mike Barile	260-373-2393	iatselocal146@comcast.net
CSC Security Operations Manager	Brent Kreider	260-480-2188	bkreider@csc-usa.com

Website
www.memorialcoliseum.com

Fax Number
260-484-1637

24/7 On-Site Assistance
260-480-2164

Booking Procedures

- **Scheduling Date:** Those with questions regarding the availability of dates should contact the General Manager at 260-482-9502.
- **Rental Expense:** Rental structure is based on established rental rates and determined by the type of event and space used. Further information can be obtained from the General Manager.
- **Contract Execution:** All arrangements are considered to be tentative until an event contract has been fully executed and returned. A deposit may be required upon execution of the event contract to secure a date.
- **Financial Settlement:** At the conclusion of the event, the licensee is responsible for settling all outstanding facility expenses. Any questions regarding the settlement process should be directed to the General Manager.
- **Event Management:** From the moment your event becomes confirmed, the Event Manager or VP of Operations will be assigned to be your primary contact with our facility. That person is your principal source of information and can be your “right hand” once you have arrived on site. He/She will take the information provided by your team and disseminate it to the appropriate facility personnel.

Ticketing & Seating

- *Ticketing:* Ticketmaster
- *Seating:* Reserved or General Admission with or without floor seats (promoter option)
- *Doors:* Reserved - 1 hour; General Admission - 1.5 hours
- *Curfew:* Midnight
- *Settlement:* Evening of event after main act has taken to the stage
- *Cash Advance:* Available with advance notice through our Ticket Office at 260-483-1111

MidWest America Ticket Office Hours

- *Monday - Friday:* 10:00am - 5:00pm and later on ticketed event days.
- *Saturday:* 10:00am - 2:00pm (during event season only)
- *Sunday:* CLOSED, except for days when there are ticketed events taking place.
- *Taxes & Fees:* No taxes on tickets. Service fees range based on ticket price.

Premium Seating

- *Luxury Suites:* 24
- *Club Seats:* 318
- *Bud Super Suite:* up to 100

Staffing

Stagehands, Riggers, Security, Runners, Production Assistants

House Staffing

Eric Lonsbury	260-480-2129	elonsbury@memorialcoliseum.com
Rich Thoma	260-480-2172	rthoma@memorialcoliseum.com

Catering

House Catering

Carol Roop
Aramark Catering Sales Manager
260-480-3711
croop@memorialcoliseum.com

Show caterer allowed with NO buyout to facility.

As required by state law, all alcohol MUST be provided through Aramark.

Merchandise

CONTACT

Ed Davidson
Aramark Food & Beverage General Manager
260-484-6486
edavidson@memorialcoliseum.com

ARENA

- Load in available through Door 18 and Docks 1 & 2
- Main location located on 100 Level next to Ice Cream Parlor (as noted on pg. 9)
- Two secondary locations located on 200 Level
- Each location can accommodate up to 8 points of sale.

The financial terms of merchandise sales may vary and are detailed in the license agreement with the venue.

Directions To Facility

- Take Interstate 69 to Exit 312A (Coldwater Rd.)
- Turn left at the 5th Stoplight (US-930/Coliseum Blvd.)
- Turn right at the 2nd stoplight (Parnell Ave.)
- Take a left into the first driveway (Entrance 4) to Docks 1 & 2 (to Arena)
- For Expo Center, take Entrance 4 to Docks 3-12

Parking Map

Allen County War Memorial Coliseum
 4000 Parnell Avenue, Fort Wayne, IN 46805 (260) 482-9502
Parking Lot Master Plan

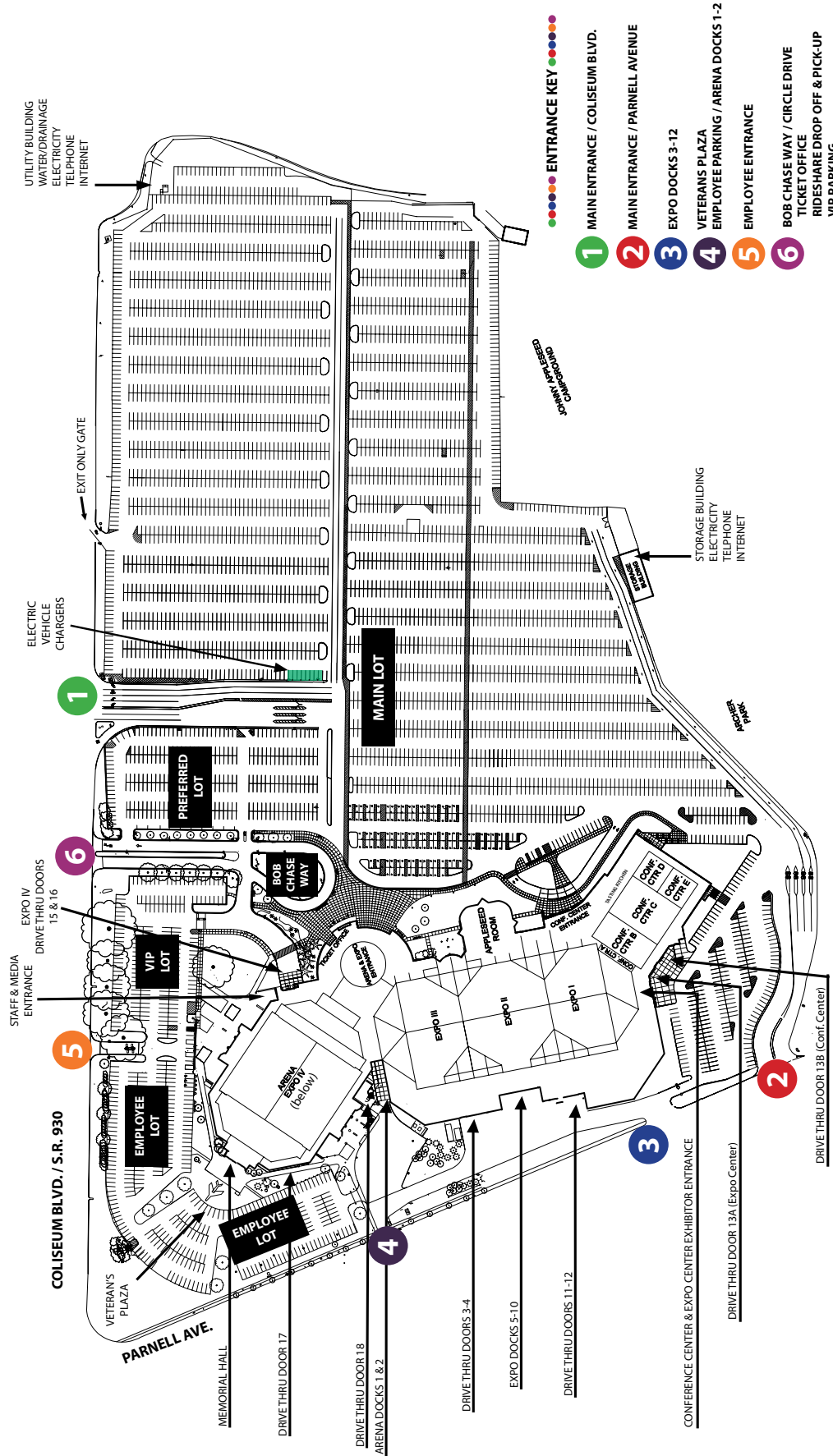

Event Marketing Services

The Allen County War Memorial Coliseum offers a full-service event marketing and media relations department to assist you in marketing your event to an audience of prospective ticket buyers and guests. We can provide comprehensive marketing plans and media buying, as well as, promotion and trade negotiation. Or, we can just answer a few questions to help you make the most out of your marketing budget.

WHAT WE DO...JUST BECAUSE

DIGITAL, SOCIAL & MOBILE

Website: www.memorialcoliseum.com with 60,000+ unique visitors per month on average.

- Events featured on website homepage, events calendar, and two banner advertisements.
- Each event has its own dedicated page with details, ticket prices, and a ticket link.

We are active across multiple social platforms and we love great content to share about our events.

Help us, help you. Connect with us!

- www.facebook.com/acwmc
- www.twitter.com/acwmc
- www.instagram.com/acwmc

ALL ACCESS ALERTS: Emails sent to over 200,000 subscribers to announce presales, onsales, special offers, and more.

DIGITAL NEWSLETTER: A monthly e-newsletter sent to our email subscribers featuring upcoming events and venue updates.

OUTDOOR MARQUEE: Our 2-sided outdoor LED marquee is near the corner of Coliseum Boulevard (US 930) and Parnell Avenue at the Northwest edge of the complex, with 65,000+ vehicles passing daily.

ARENA SCOREBOARD: During our sports season, we can play your TV commercial on the center-hung scoreboard during intermissions and halftimes of Komets, Mad Ants & Mastodons games. SPECS: uncompressed .MOV or .MP4 video file required.

CLOSED CIRCUIT TELEVISIONS: With over 150 television monitors throughout the building, we reach the captive audiences by promoting upcoming events in a slideshow format.

MEDIA RELATIONS: Each week, we send a calendar of public events "press release" out to a list of local, state and regional media outlets across all platforms. Additionally, we can send out event-specific press releases as-needed for event announcements and ticket on-sales. We can also help arrange print and radio interviews, as well as, advance media tours.

CASH, TRADE & PROMOTION

To receive list of local media outlet sales representatives, contact our Marketing Communications Coordinator.

We can provide these buying and negotiation services at no additional cost.

TELEVISION

Network Affiliates - CBS, ABC, NBC, CW, MyTV, FOX, PBS

Comcast Cable (Fort Wayne, Warsaw, South Bend, Mishawaka, Elkhart, Muncie, Marion, Indianapolis)

RADIO

A full array of radio formats are available in the market:

Contemporary Christian, Public Radio, AM/FM Talk, Sports Talk, Country, Adult Contemporary, Active Rock, Classic Rock, Classic Hits, Urban, CHR etc.

NEWSPAPER

- *Fort Wayne Newspapers* - Journal Gazette (morning daily)
- *Whatzup* - weekly, free entertainment newspaper with local coverage
- *El Mexicano* - area's largest Spanish language publication, reaching the large Hispanic population
- *Ad-Net* - buying service that reaches 9 outlying area counties with smaller local newspapers

OUT OF HOME

Traditional and Digital Billboards, Mall Advertising Panels, Digital Indoor Ads, Cinema, etc.

Graphics Specs & Sizes

Website (808x504 AND 1178x531): This will display on the home page of our website and on the event details page of your event. Please keep images free of text and logos (if applicable).

Outdoor Marquee (450x160): Graphic should include photos and basic text. We will add date and time info.

Indoor TV System (1920x1080): Graphic including event artwork, date and time.

Social Media:

Facebook Event Cover Photo: 1200x628

Facebook Feed/Instagram: 1080x1080

Twitter/X: 1200x628

Online Ads (for Whatzup):

Footer: 728px x 90px

Miscellaneous: If you have any high resolution photos of the artist that we could use for promotional purposes, please send them to us.

We can create it! Send us high quality, original artwork (Photoshop files appreciated) and we can design graphics to the various sizes needed.

Questions? Contact our Marketing Communications Coordinator at 260-480-3709.

Arena Ribbon Board & Scoreboard Display Specs

PREFERRED FILE TYPES

Motion: .MOV (if alpha elements)
or .MP4

Static: .PNG (Preferred)
.BMP or .JPG

Arena Corner “Stat” Boards
220w x 140h

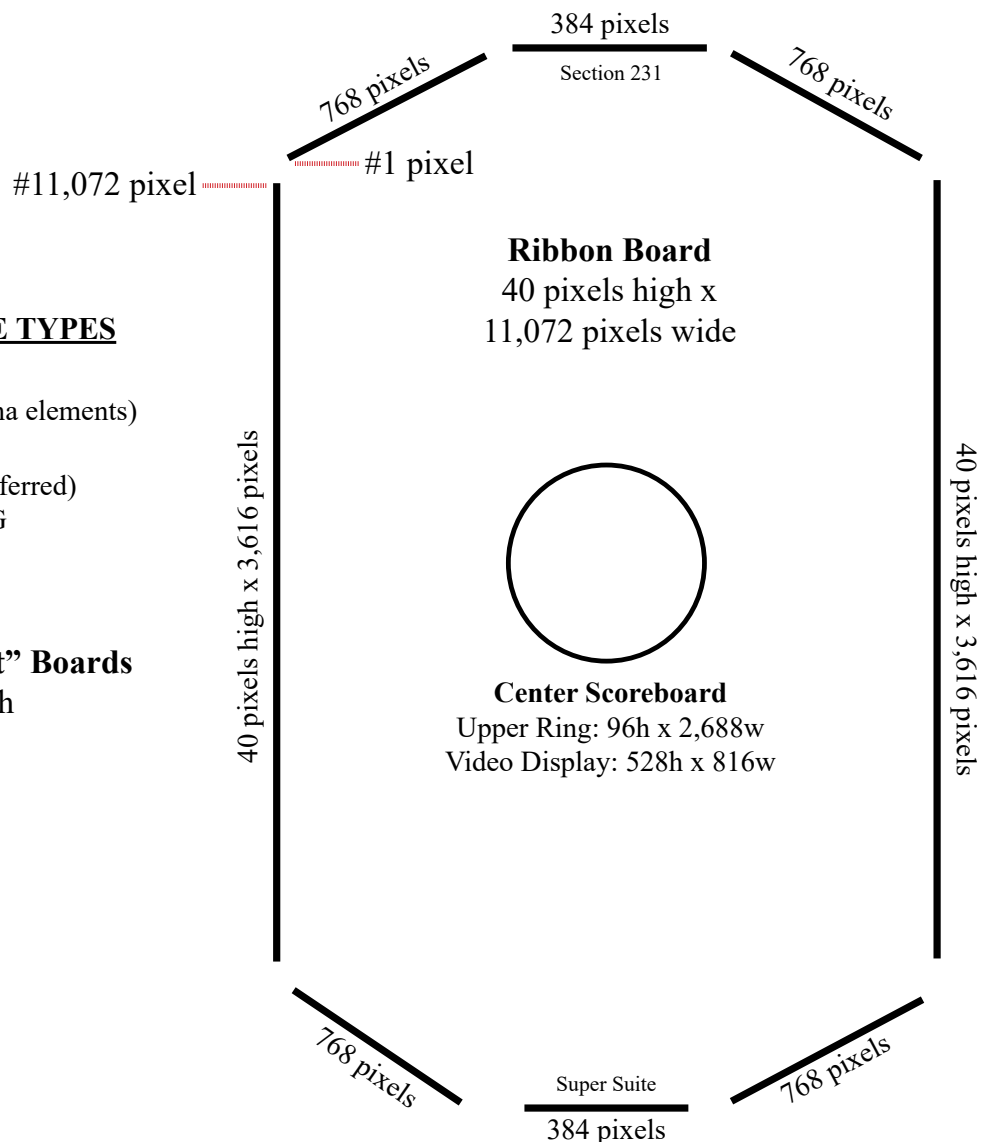

Scoreboard Dimensions

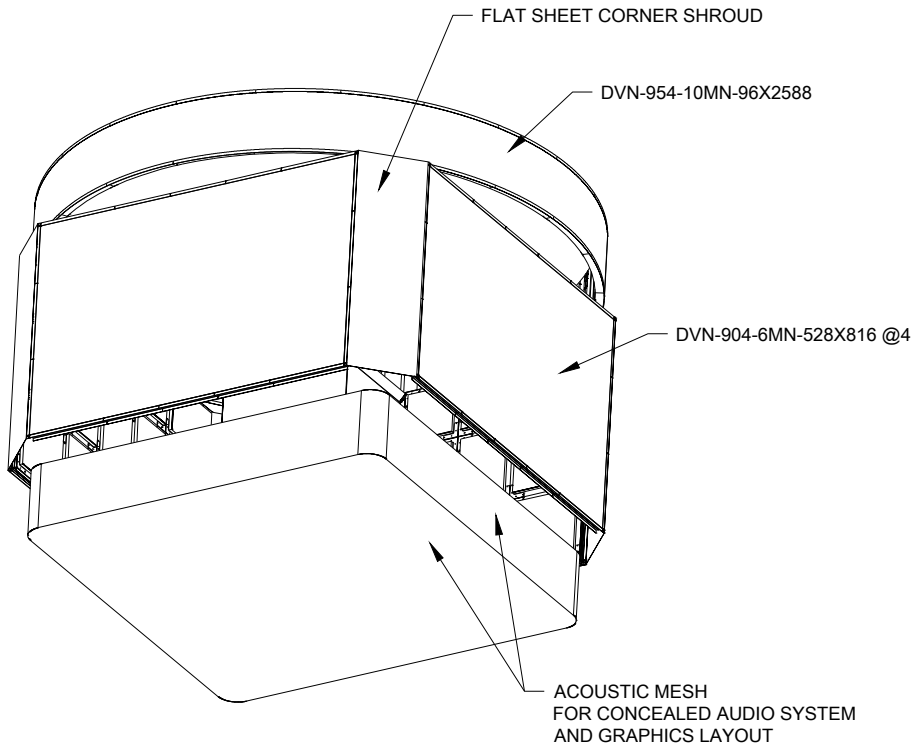

ISOMETRIC VIEW

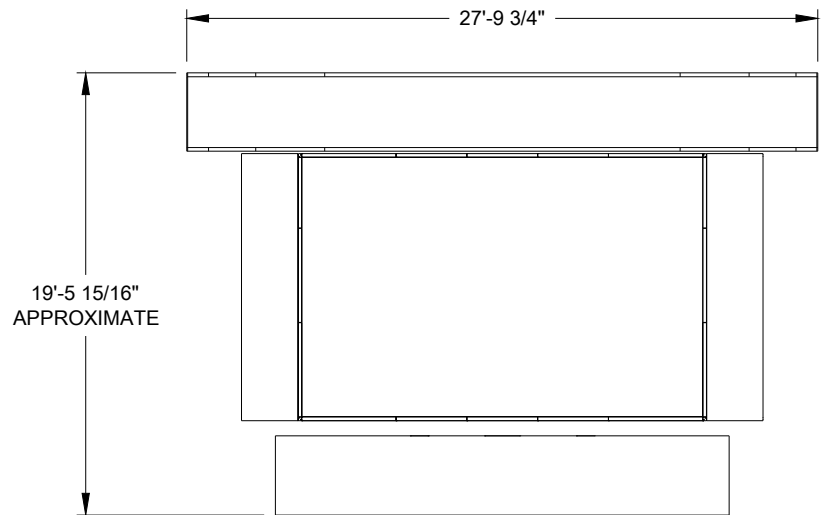
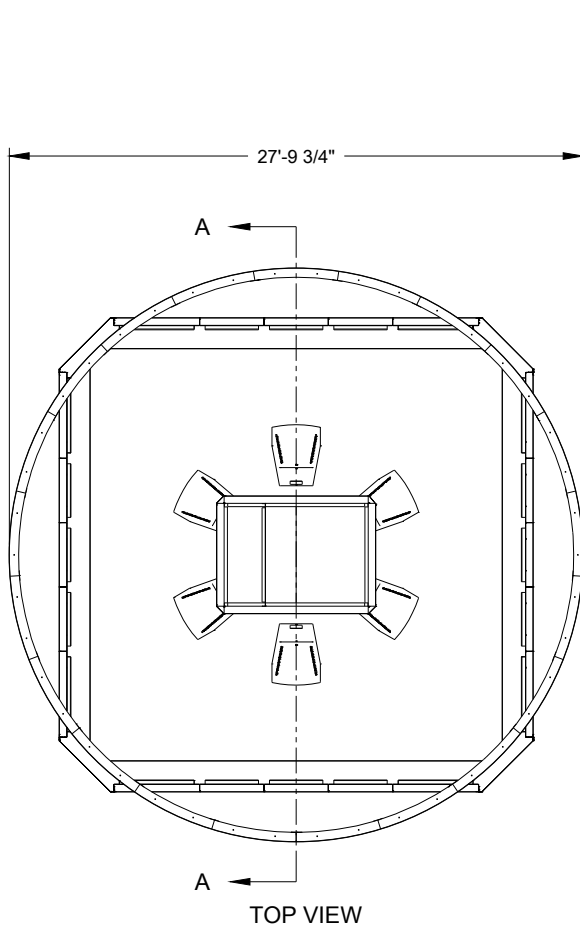

FRONT VIEW

Rental Rates

To view all 2022-2023 rental rates, including

- Room Rental
- Equipment & Personnel

Visit our website at www.memorialcoliseum.com/plan-an-event.

Transportation

FORT WAYNE INTERNATIONAL AIRPORT (FWA)

Fort Wayne International Airport (FWA) serves Northeast Indiana with four airline carriers, offering over 140 non-stop departures each week to major cities including Atlanta, Charlotte, Chicago, Dallas/Fort Worth, Detroit, Philadelphia and more. FWA is located on the Southwest side of Fort Wayne, 20 miles away from the Memorial Coliseum.

GROUND TRANSPORTATION

Car Rental Agencies

Alamo/National

Reservations: 800-227-7368

FWA Office: 260-747-2673

Avis

Reservations: 800-331-1212

FWA Office: 260-747-2471

Budget

Reservations: 800-527-7000

FWA Office: 260-478-2507

Dollar

Reservations: 800-800-4000

FWA Office: 260-478-2014

Enterprise

Reservations: 800-736-8222

FWA Office: 260-478-8715

Hertz

Reservations: 800-654-3131

FWA Office: 260-747-6108

Thrifty

Reservations: 800-847-4389

FWA Office: 260-478-2013

Transportation Network Companies

Lyft

Uber

Taxi Services

A-1 Deluxe • 260-410-7589

American Taxi • 260-446-7429

Economy Taxi • 260-515-5778

Taxi by Simone • 260-267-1533

Yo Taxi • 260-403-6455

1st Class Taxi • 260-387-9193

Limo Services

A-1 Deluxe • 260-410-7589

Club Car Limo • 260-492-2102

Premier Limousine • 260-748-2266

Luxury Limousine • 260-747-7127

AA Elegant Limousine • 260-486-5059

Local Resources

HOTELS *(sorted by distance from facility)*

Holiday Inn Purdue - Fort Wayne • 260-482-3800
4111 Paul Shaffer Dr., Fort Wayne, IN 46825

TownePlace Suites by Marriot FW North • 260-483-1160
3949 Ice Way Dr., Fort Wayne, IN 46805

Sonesta Select Fort Wayne • 260-471-8522
111 W. Washington Center Rd., Fort Wayne IN 46825

Candlewood Suites Fort Wayne - NW • 260-484-1400
5251 Distribution Dr., Fort Wayne, IN 46825

Tru by Hilton Fort Wayne • 260-444-2500
5345 Distribution Dr., Fort Wayne, IN 46825

Comfort Inn • 260-489-2220
1005 W. Washington Center Rd., Fort Wayne, IN 46825

Hampton Inn & Suites Ft. Wayne - North • 260-489-0908
5702 Challenger Pkwy., Fort Wayne, IN 46818

Wyndham Garden Fort Wayne • 260-209-1478
5750 Challenger Pkwy., Fort Wayne, IN 46818

Best Western Plus Fort Wayne Inn & Suites North • 260-490-6060
5926 Cross Creek Blvd., Fort Wayne, IN 46818

Fairfield Inn & Suites by Marriott Fort Wayne • 260-442-3040
6021 Lima Rd., Fort Wayne, IN 46818

Quality Inn • 260-489-5554
1734 W. Washington Center Rd., Fort Wayne, IN 46818

PHARMACIES

Kroger Pharmacy
4120 N. Clinton St., Fort Wayne, IN 46805
260-483-3185

CVS Pharmacy
3801 Coldwater Rd., Fort Wayne, IN 46805
260-470-6361

Walgreens Pharmacy
5830 N. Clinton St., Fort Wayne, IN 46825
260-483-2191

Walmart Pharmacy
5311 Coldwater Rd., Fort Wayne, IN 46825
260-484-4528

Meijer Pharmacy
6309 Lima Rd., Fort Wayne, IN 46818
260-497-1010

FITNESS CENTERS

Anytime Fitness
6520 E. State Blvd., Fort Wayne, IN 46815
260-240-2400

Planet Fitness
4530 Maplecrest Rd., Fort Wayne, IN 46835
260-485-7979

Spiece Fitness
5310 Merchandise Dr., Fort Wayne, IN 46825
260-483-1415

Catalyst Fitness - Northeast
5928 Trier Rd., Fort Wayne, IN 46815
260-485-1671

HOSPITALS

Dupont Hospital
2520 E. Dupont Rd., Fort Wayne, IN 46825
260-416-3000

Lutheran Hospital of Indiana
7950 W. Jefferson Blvd., Fort Wayne, IN 46804
260-435-7001

Parkview Regional Medical Center
11109 Parkview Plaza Dr., Fort Wayne, IN 46845
260-266-1000

GAS STATIONS

Marathon Gas
4233 N. Clinton St., Fort Wayne, IN 46805
0.5 miles away | 2 minutes away

BP
909 E. Coliseum Blvd., Fort Wayne, IN 46805
0.4 miles away | 2 minutes away

Shell
1051 E. Coliseum Blvd., Fort Wayne, IN 46805
0.4 miles away | 2 minutes away

Sunoco
5133 Coldwater Rd., Fort Wayne, IN 46825
1.3 miles away | 4 minutes away

Speedway
3210 Stellhorn Rd., Fort Wayne, IN 46815
1.4 miles away | 3 minutes away

Load In



- Arena Loading Docks: 2
- Trucks Can Stay At Dock
- 75' Push - Up Stage Center

★ Marked on the Arena map as Dock Doors #1 and #2



- Ramp Off Truck: Yes
- Drive Into Building: Yes
- 11' Clearance
- Direct Access to Floor

★ Marked on the Arena map as Door #18

Load In

Marshalling Area / Bus Parking - 400 amps of Shore Power Available



Excess Truck/Bus Parking - Six-50 amps connects of Shore Power Available



Rigging

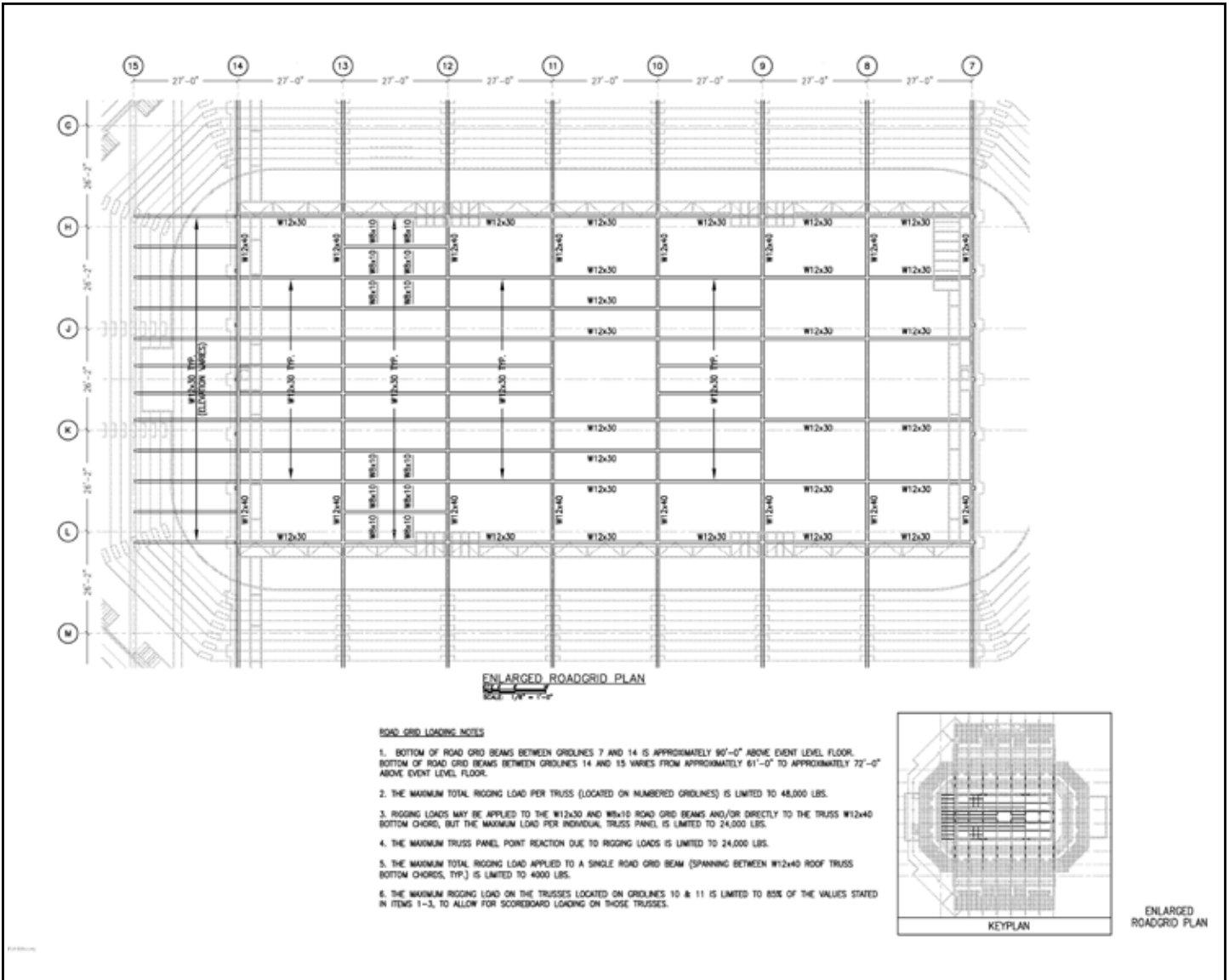

- Rigging Grid rated for 125,000 lbs.

- NOTE: Rigging Grid is at 90'. The most efficient rigging call is 2 UP for every 1 DOWN for load in/out.

Power

- | | | |
|--------------------------|-----------------|-----------------|
| • Up Stage Center (20') | (2) 600 amp 3ph | (1) 200 amp 3ph |
| • Down Stage Right (30') | (1) 400 amp 3ph | (1) 200 amp 3ph |
| • Down Stage Left (30') | (1) 400 amp 3ph | (1) 200 amp 3ph |
| • Front Of House (FOH) | (1) 200 amp 3ph | |

Building has 100' of 400 amp and 200 amp feeder if needed.

Shore Power

Six (6) 50 amp outlets at Dock #1 and #2

Six (6) 50 amp outlets in Adjacent Truck Parking Lot

*House Electrician on site.

Staging

STAGE RIGHT STAGING

- | | |
|-----------------------|--------------------|
| • Maximum Size | 80' x 40' |
| • Height | 4' x 6' |
| • Weight Restrictions | 125 lbs per sq ft. |
| • Steps | 4 |
| • Handrails | Yes |
| • Toe Rail | Yes |
| • Skirting | Yes |

BARRICADE

Staging Concepts: 176' Blow Through Barricade with 4 Inside and 4 Outside Corners and 2 Cable Pass Thru's.

RISERS

Available: 48" x 4'

STAGE WINGS

Available: 16' x 24'

Curtains

Full Upper Bowl Masking Drape

Spotlights

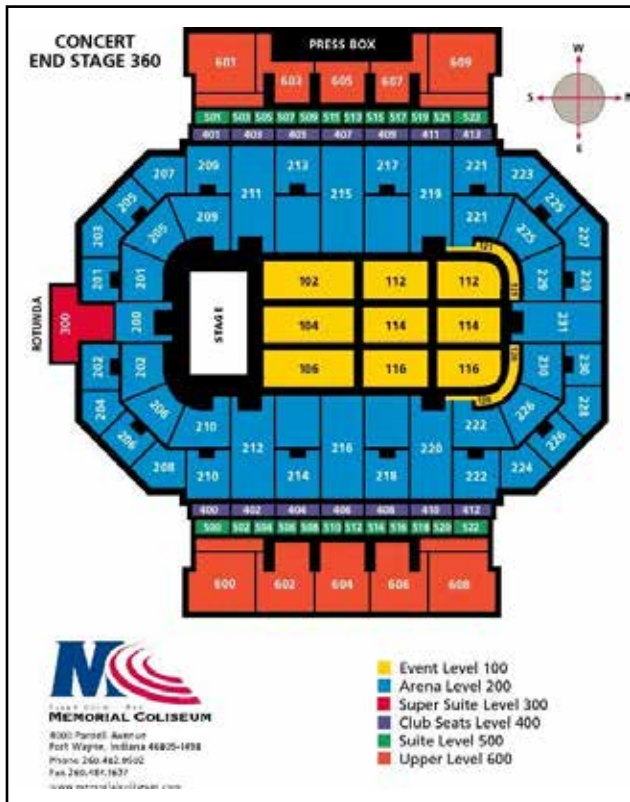

Located on Fixed Platforms

- Xenon Gladiators (10)
- Section 211, 212, 215, 216, 219, 220, 227, 228, 230 (2)
- Xenon Super Troupers (2)
- Section 203, 204

Available for Alternate Locations

- Xenon Super Troupers (2)
- Lycian 400 (2)

Clear-Com available at all spot locations.
Dry line hookup location Up Stage Center.

House Light location in Press Box above Section 605
(House operates House Lights)

Forklifts

- (3) Nissan 5000# 12' Reach Side Shift Gas
- (1) Nissan 3000# 14' Reach Side Shift Gas

One Set of 6' and 8' Fork Extensions Available In-House

Additional Forklift Rental

Nissan Forklift
Scott Maser
260-482-9471

Other Available Equipment In-House

20' Scissor Lift
30' Scissor Lift
50' Genie Lift

Pyro/Haze

- Pyro/Haze may be used in facility. Copy of license and details on pyro used in show must be supplied to the Operations Manager two (2) weeks prior to show for Fire Marshal approval. City Pyro Permit must be applied at no cost.
- You must notify House operations prior to using any pyro or haze so they can zone out the Fire System.
- A Fire Watch is required for any use of pyro/haze.
- An additional Certificate Of Insurance is required for pyro/haze.

House Capacity

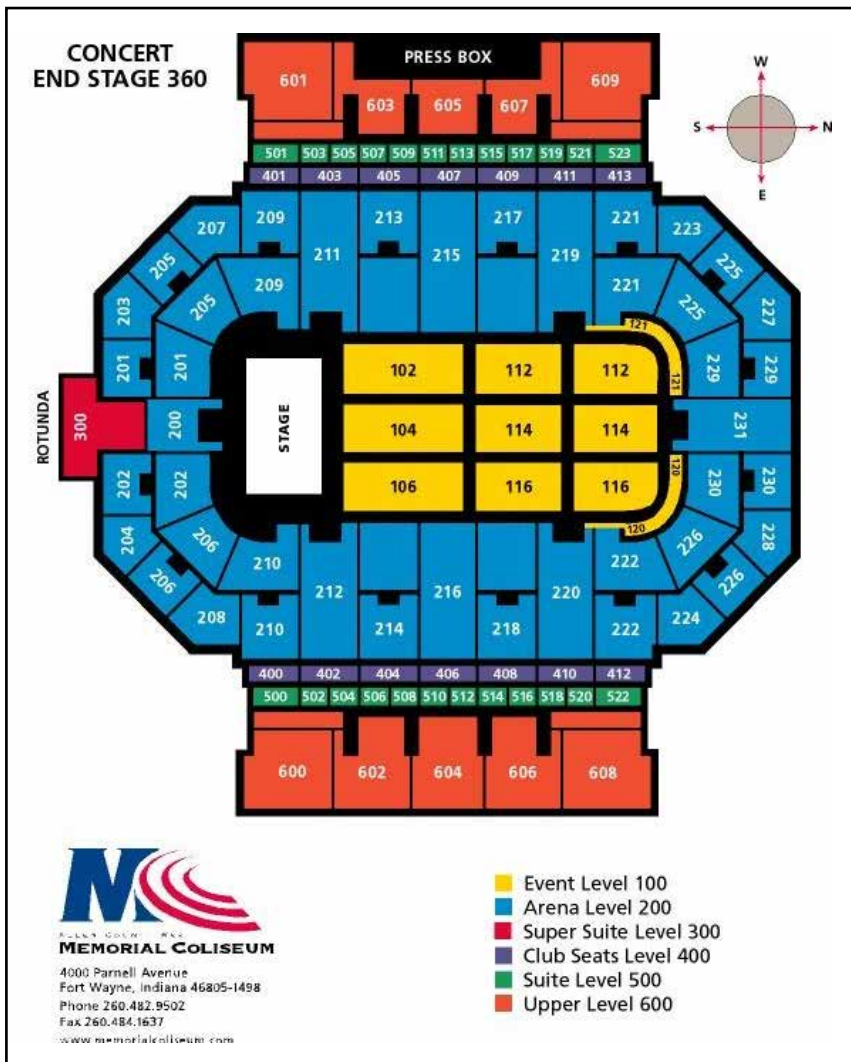

FULL HOUSE

12,500

HALF HOUSE

6,000

FRONT OF HOUSE

4,000

Seating Chart Sample: Arena

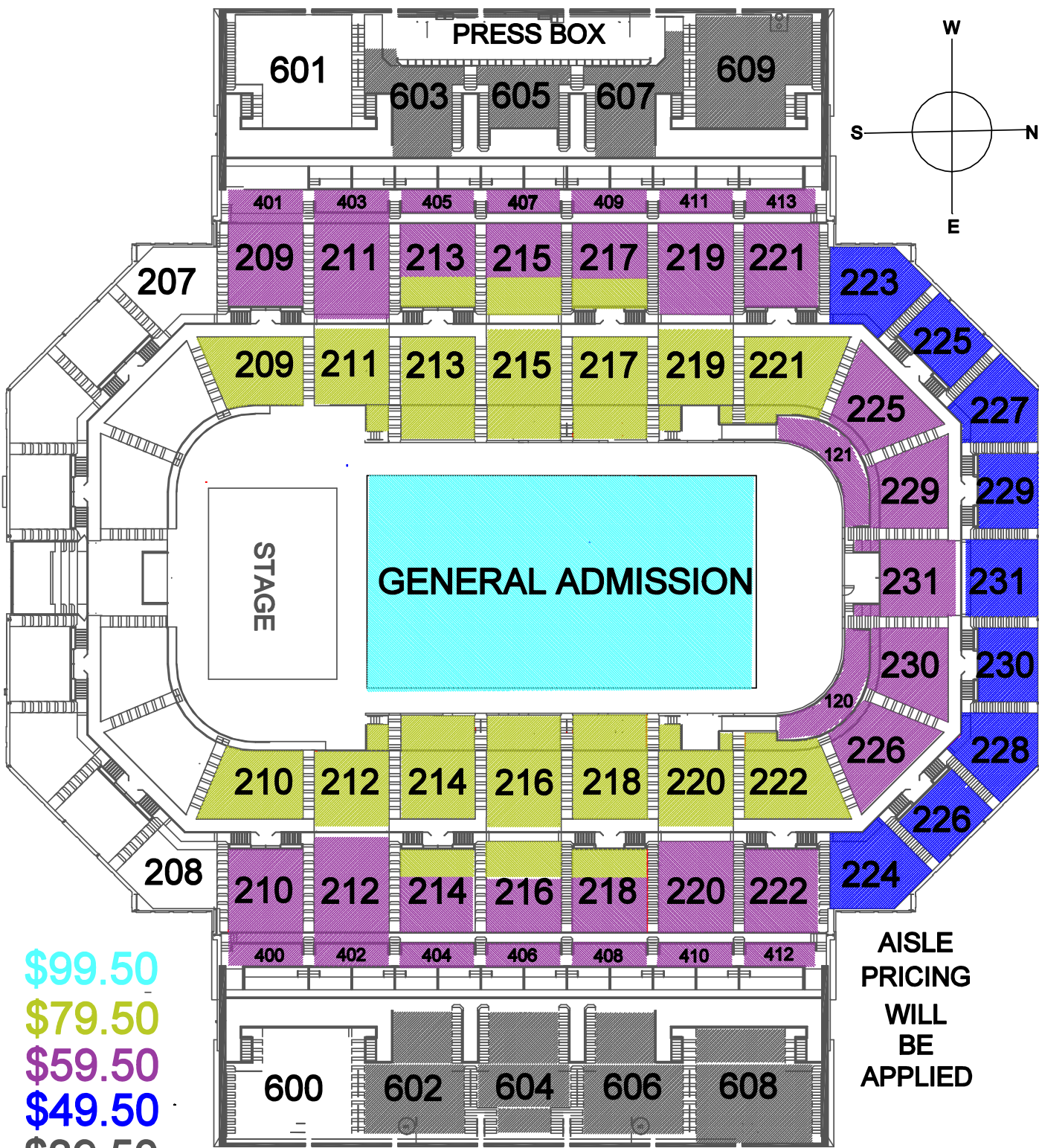

- \$99.50
- \$79.50
- \$59.50
- \$49.50
- \$39.50

Set Up Photos: Arena

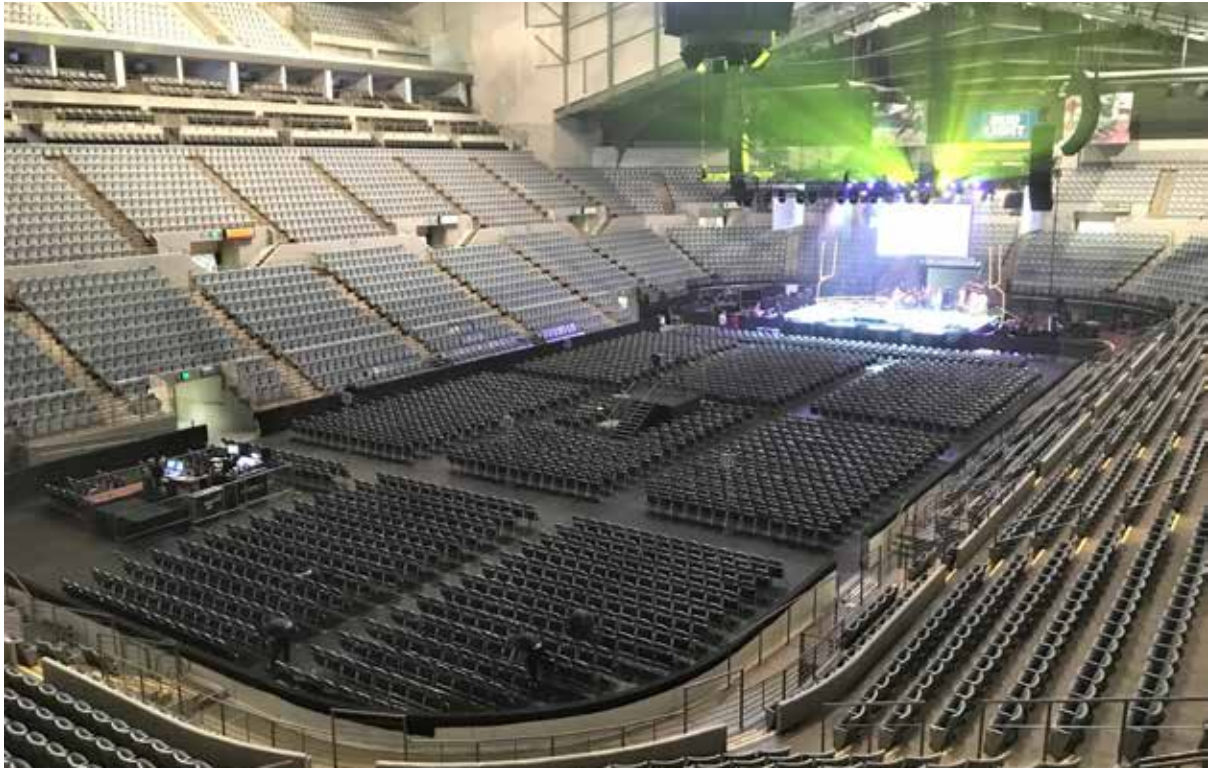

Dressing Rooms & Backstage Area

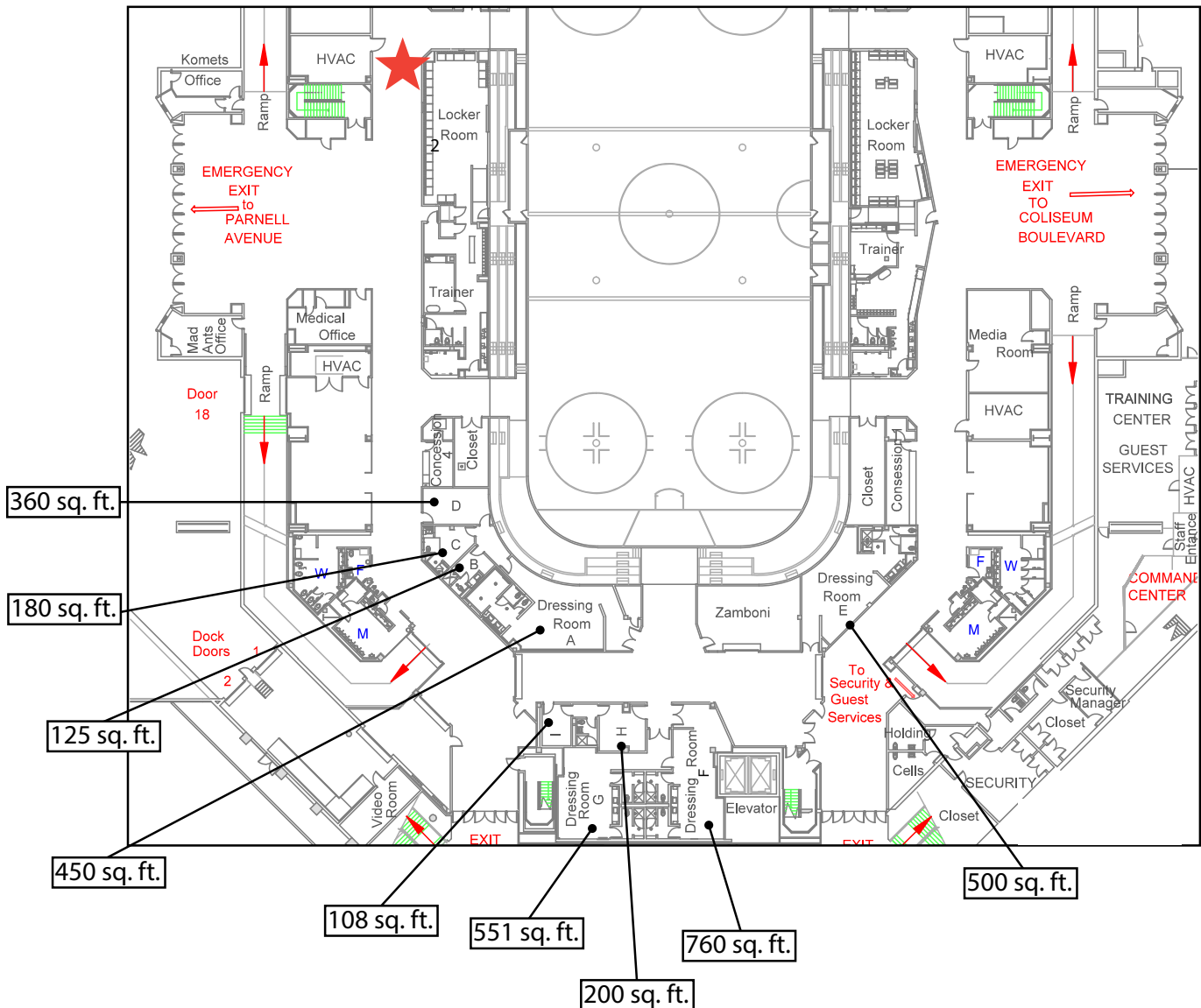

Dressing Room Sizes

- A: 450 sq. ft.
- B: 125 sq. ft.
- C: 180 sq. ft.
- D: 360 sq. ft.
- E: 500 sq. ft.
- F: 760 sq. ft.
- G: 551 sq. ft.
- H: 200 sq. ft.
- I: 108 sq. ft.

ALL ROOMS

- Showers & Toilet (except Room D)
- Telephone Access
- Internet Access
- Backstage Monitoring Available

★ Locker Room 2

- Center of house SL
- Showers & Toilet
- Telephone Access
- Internet Access

Furniture Rental
Rent-A-Center
260-426-3735

CO2/Extinguishers
Nowak Supply
260-424-1901

Dressing Rooms & Backstage Area



Room A: 450 sq. ft.



Room B: 125 sq. ft.



Room C: 180 sq. ft.



Room D: 360 sq. ft.



Room E: 500 sq. ft.

Dressing Rooms & Backstage Area



Room F: 760 sq. ft.



Room G: 551 sq. ft.



Room H: 200 sq. ft.



Room I: 108 sq. ft.

★ LOCKER ROOM 2



View #1



View #2

Additional Rooms Available

MEDIA ROOM



Can be used for media staff or as a work room for four personnel.

CENTURY CLUB



1,900 square feet • Can be utilized for VIP and Meet & Greet events.

APPLESEED ROOM



8,100 square feet • Can be utilized for VIP & Meet & Greet events based on availability.
NOTE: This room is not included in the Arena rent.

Arena Access to Red & White Rooms



Both Red & White Rooms are 1,700 square feet and can be utilized for VIP and Meet & Greet events.

Map Key

	WOMEN'S RESTROOM		FIRST AID
	MEN'S RESTROOM		WATER FOUNTAINS
	ELEVATOR		HANDICAP ACCESSIBLE SEATING
	EMERGENCY EXIT		

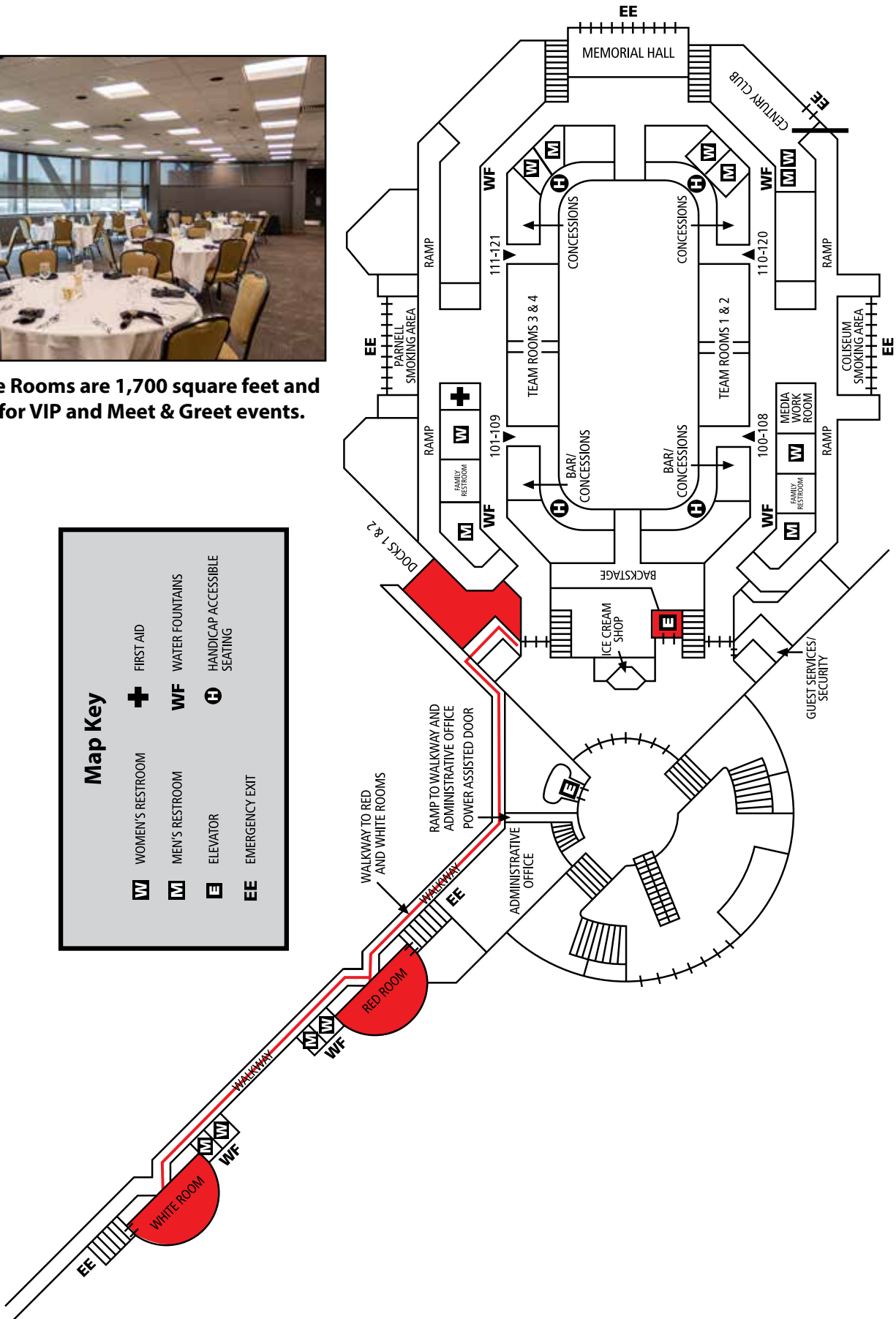

EXPO CENTER

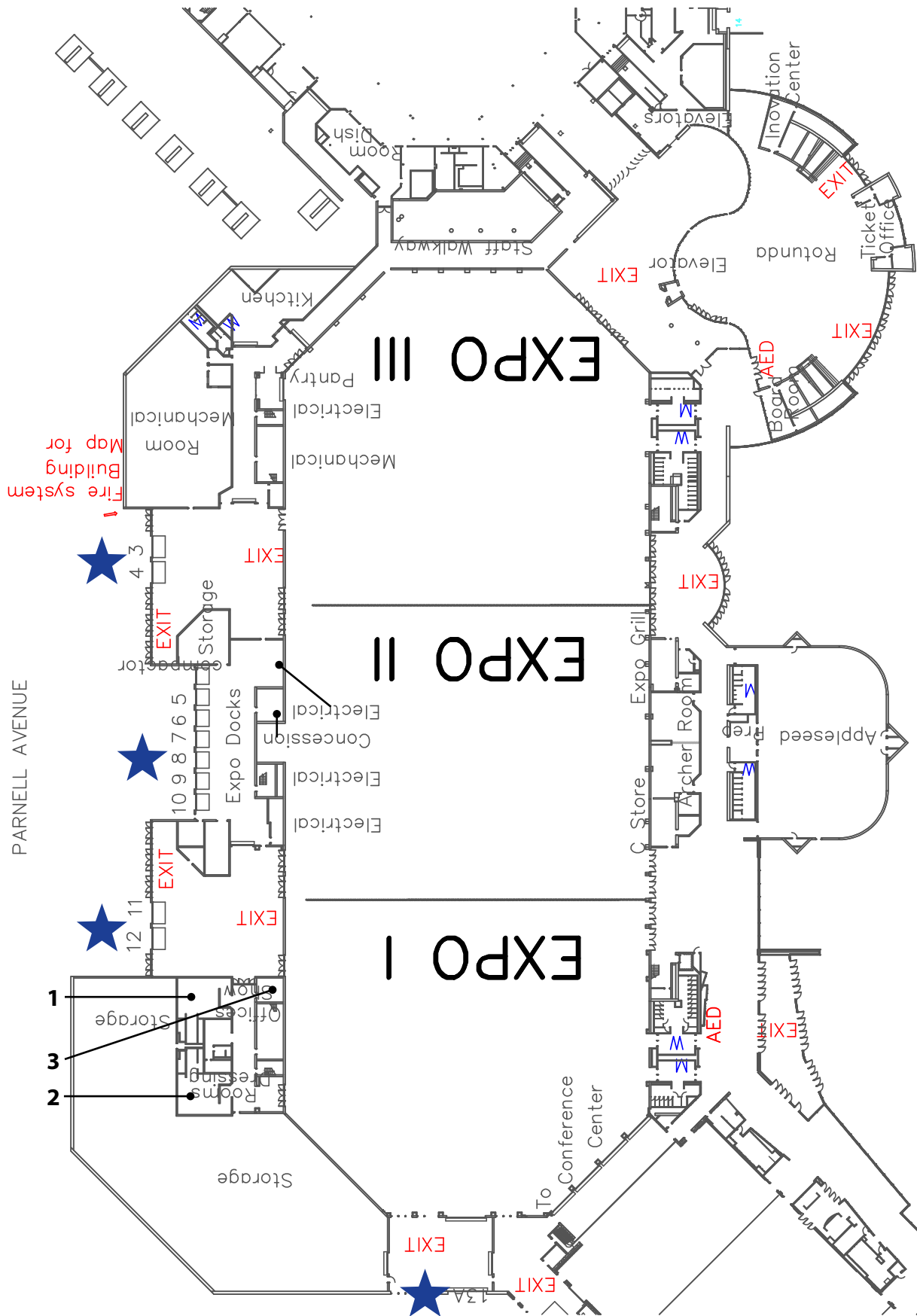

Load In

- Docks 3-13; 15 and 16 to Expo IV
- Trucks can stay at docks 5-10
- Ramp Off Truck: Yes - direct access to floor
- Ability To Drive Into Building: Docks 3 and 4, 11-13, 15 & 16 (11' Clearance)
- Additional Truck Parking: Adjacent to Docks 3-12; Abundant Off-Street Parking
- Marshalling Area/Bus Parking: 400 amp of shore power available
- Shore Power available at docks: 100 amp

Docks 3-12



Docks 3 & 4



Docks 5-10



Inside Docks 5-10



Docks 11 & 12



Dock 13A (South End of Expo)



Capacities/Set-Ups

Maximum Capacity

Concert/Theatre: 1,000-7,000

Banquet: 5,000

Classroom: 3,000

Total Dimensions

540' x 200'

Square Footage

108,000 sq. ft. (Divisible into 3 separate spaces)

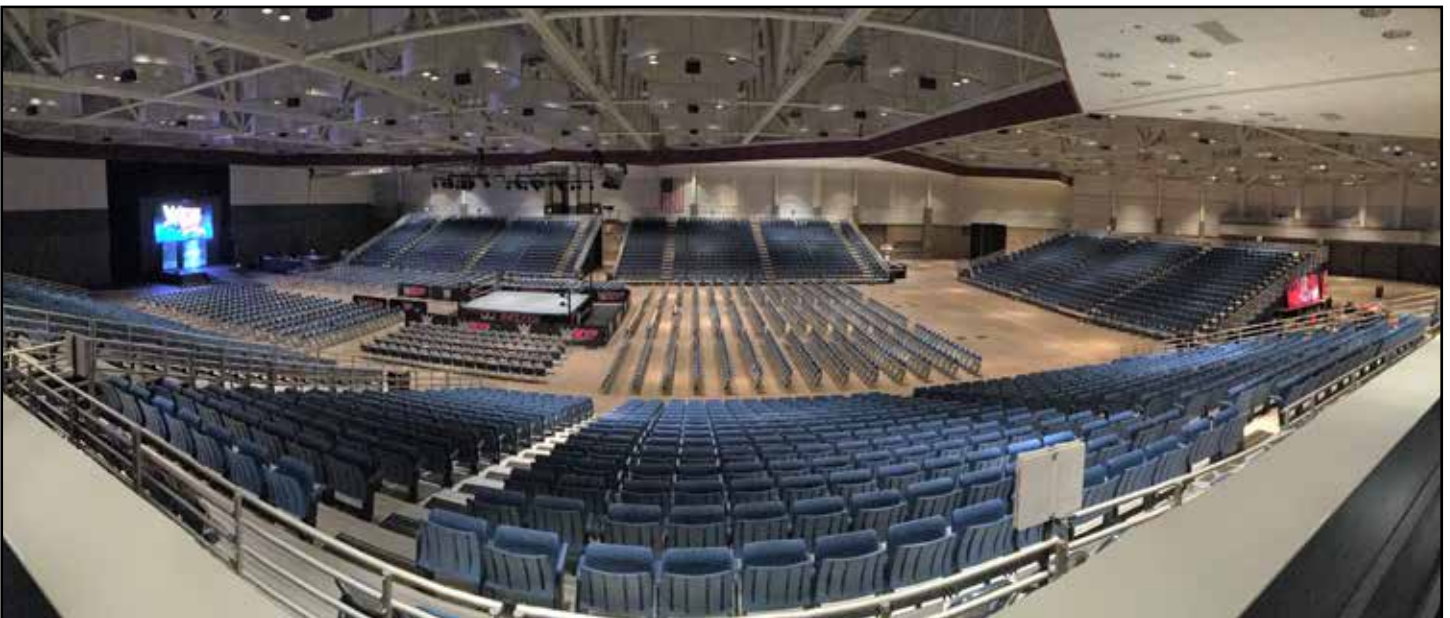

Capacities/Set-Ups

TRADE SHOW



MEETING/BANQUET



Four large overhead doors located on the south side of the room open to allow the Expo Center and Conference Center to work as one contiguous space, with 130,000 square feet.

Seating Chart Sample: Expo Center

SEATING FOR 3,000 GUESTS

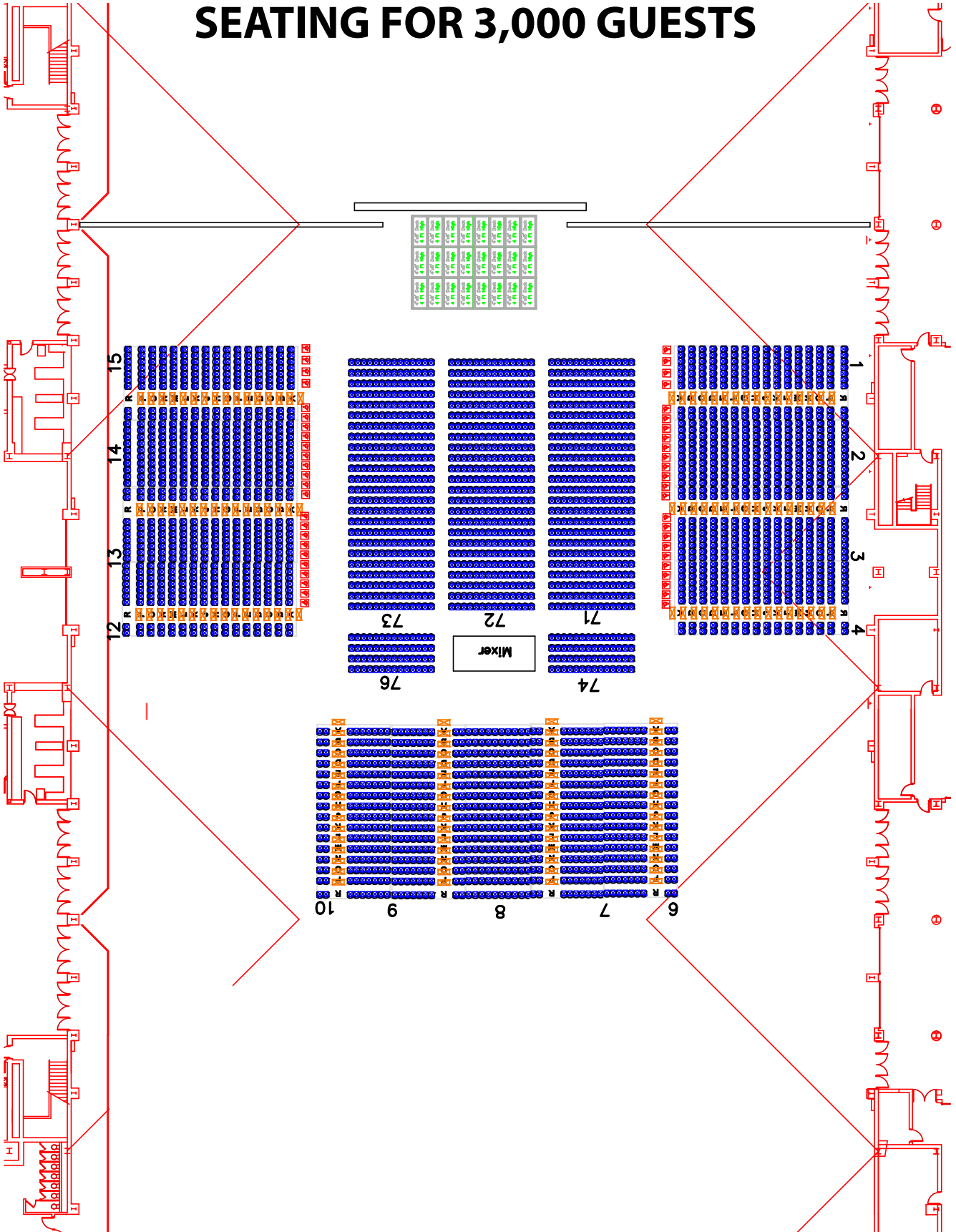

Seating Chart Sample: Expo Center

SEATING FOR 6,000 GUESTS

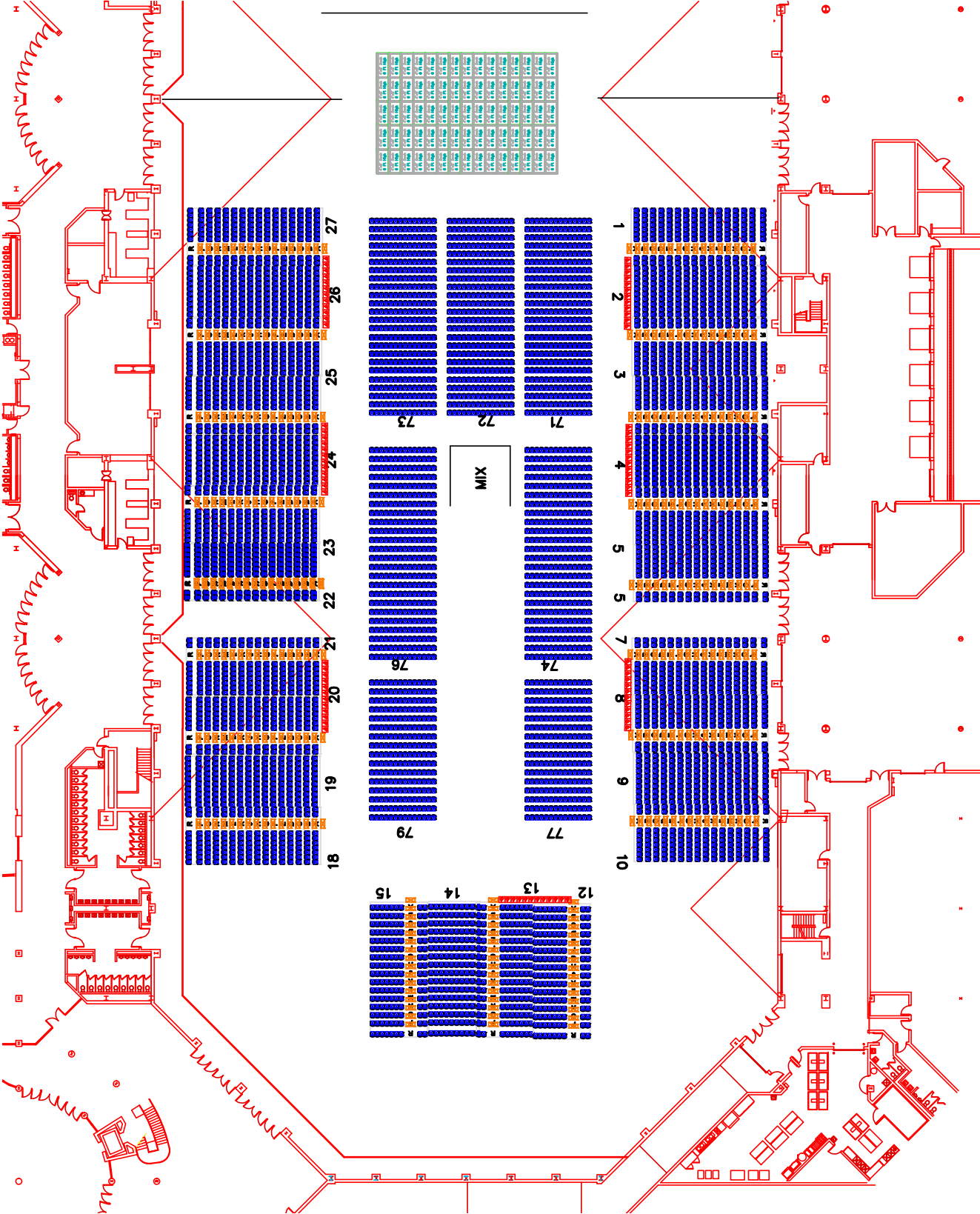

Rigging

- 2,000 lb. limit per point without bridle
- 8 I-beams center and every 15' stage right and left
- 38' to truss - floor to beam
- 47' to rigging steel (grid to hang from)
- 20 beam claps available

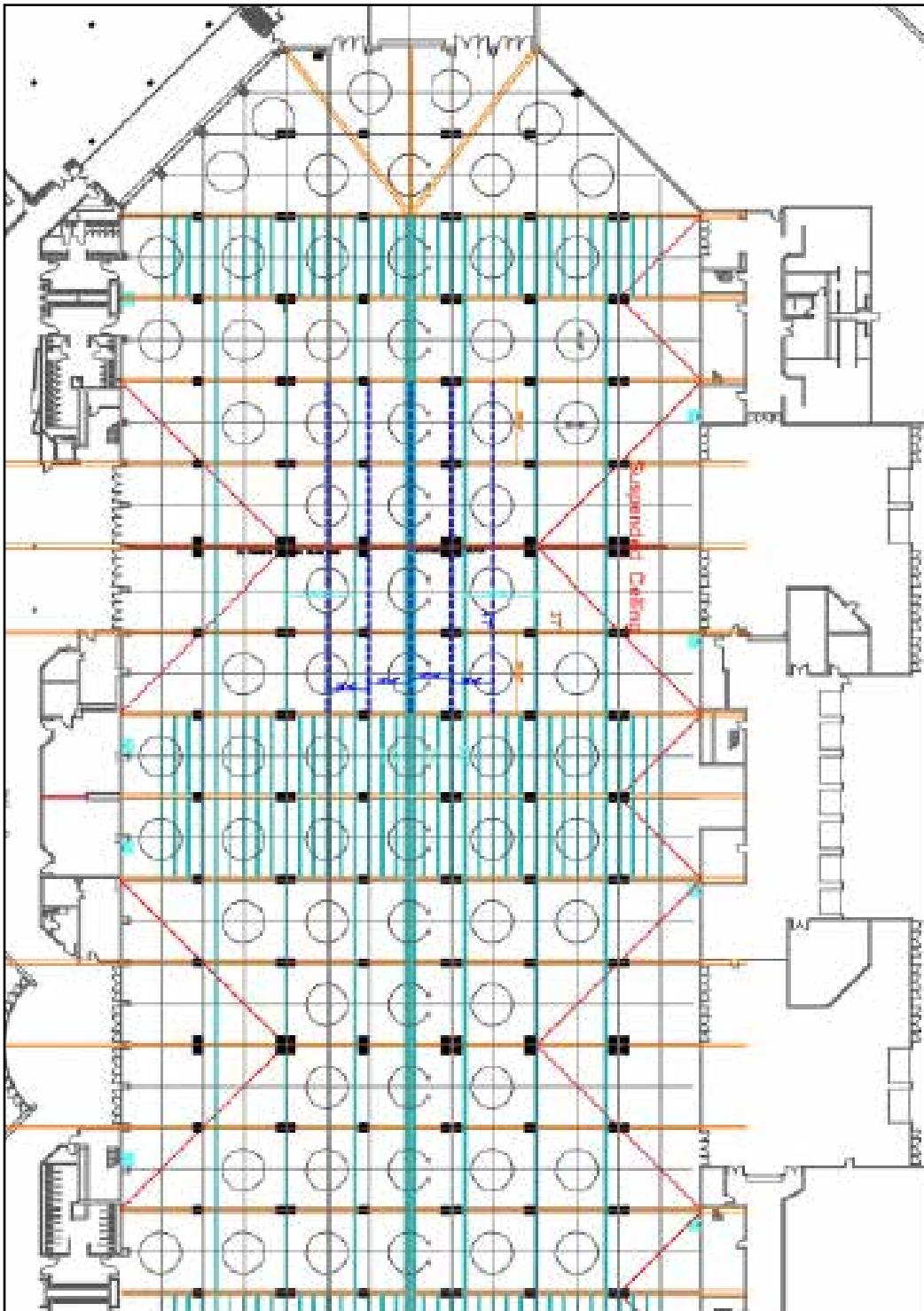

Power

- Stage Right (75') (2) 600 amp 3ph
- Stage Right (75') (1) 400 amp 3ph
- Stage Right (75') (1) 200 amp 3ph

60 amp 3ph - every 30' throughout floor

Staging

STAGE RIGHT STAGING

- Maximum Size 80' x 40'
- Height 4' x 6'
- Weight Restrictions 125 lbs per sq ft.
- Steps 4
- Handrails Yes
- Toe Rail Yes
- Skirting Yes

BARRICADE

Staging Concepts 176' Blow Through Barricade with 2 Inside and 2 Outside Corners.

RISERS

Available: 48" x 4'

STAGE WINGS

Available: 16' x 24'

(Same staging amenities as Arena)

First Floor Master Plan

Expo I, II & III Utilities

- A, C, E 480V 3PH 60A
- 208V 3PH 60A
- 6 110V 20A
- Water/Drain
- Compressed Air
- Telephone/Internet
- B, D, F 208V 3PH 60A
- 6 110V 20A
- Telephone/Internet

Floor saw-cuts are 15'x15'
Utility boxes are 30' on center

Conference Center Utilities

- 208V 3PH 60A
- 6 110V 20A
- Telephone/Internet

Applesed Room Utilities

- 110V 20AMP

Expo IV Utilities
Columns are 27' on-center
110V/20A electricity is
available on each column
Telephone/Internet
Available on each column

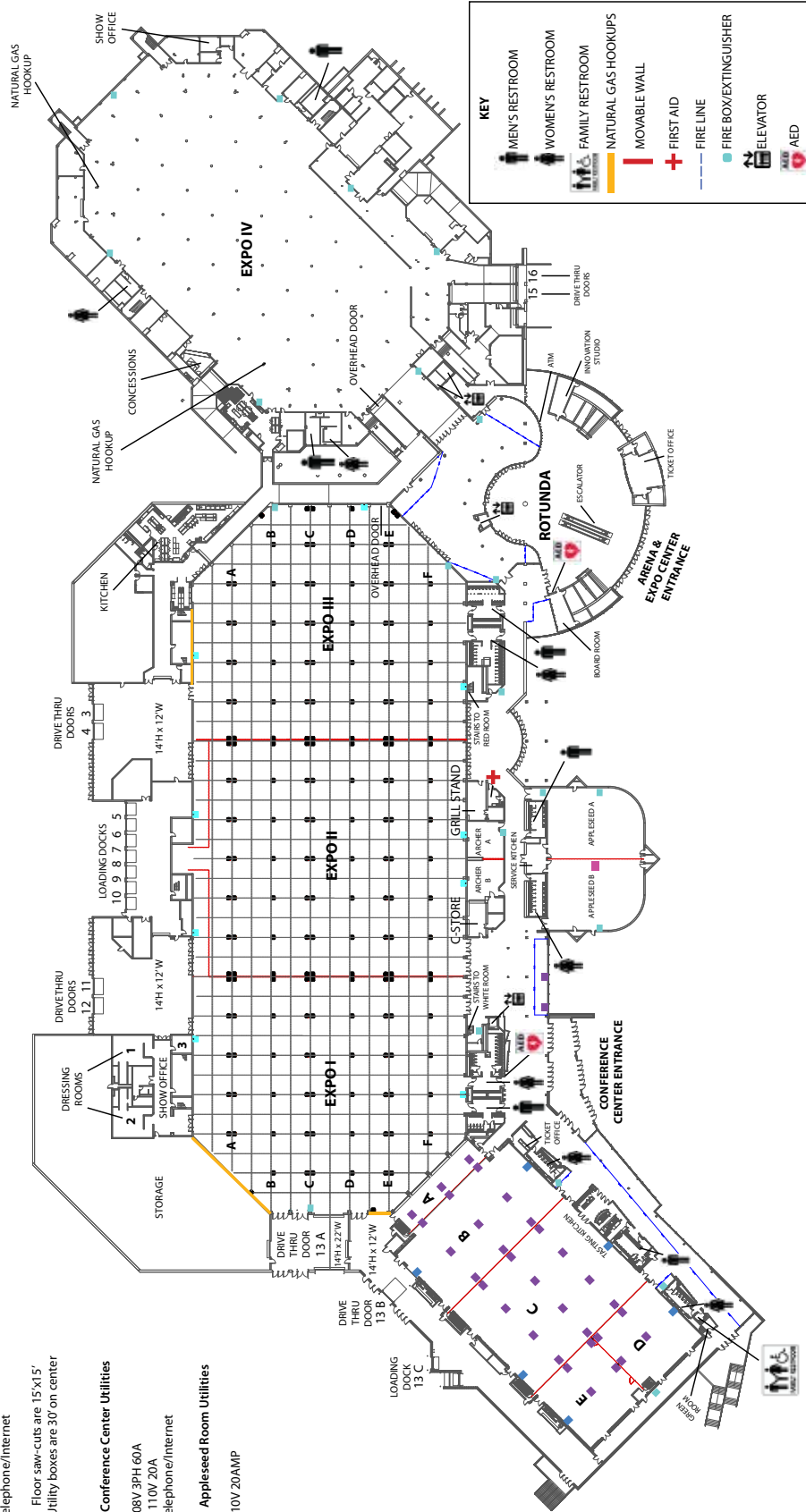

Equipment

Spotlights

- (2) Movable Xenon Super Troupers
- (2) Movable Lycian 400

Intercoms

Clear-Com available with cable at all spot locations

Forklifts

- | | | | |
|--------------------|-----------|-----------------|-----|
| • (1) Nissan 7000# | 12' Reach | Fork Extensions | Gas |
| • (3) Nissan 5000# | 12' Reach | Fork Extensions | Gas |
| • (1) Nissan 3000# | 14' Reach | Fork Extensions | Gas |

Telecommunications

- Telephone lines, internet hookups or other specialty requirements can be made through the Information Technology Department.
- Rates are based on usage.

Dressing Rooms & Offices



Chorus Size Dressing Room #1

- 846 sq. feet
- 100' Stage Left
- Bathroom & Shower Included



Chorus Size Dressing Room #2

- 816 sq. feet
- 100' Stage Left
- Bathroom & Shower Included

Dressing Room #3 available



Expo Center Show Office

- 459 sq. feet
- 100' Stage Left
- Connection To Second Show Office
- Lockable Storage Room
- Leather Couches
- Office Desk and Chair
- Bathroom and Shower